

NOVEL METHOD FOR THE INVESTIGATION OF THE SHEAR PROPERTIES OF GLASS FABRIC REINFORCEMENTS

Ábris Dávid Virág¹, Kolos Molnár^{1,2}, Marianna Halász¹

¹ *Department of Polymer Engineering, Faculty of Mechanical Engineering, Budapest University of Technology and Economics, Műegyetem rkp. 3. H-1111, Budapest (Hungary)*

² *MTA–BME Research Group for Composite Science and Technology, Műegyetem rkp. 3., H-1111, Budapest (Hungary)*

Abstract

Woven glass fabrics is one of the most commonly used fibrous structures for reinforcing thermoset matrix polymer composites. Considering the 3D shape of the composite products, during manufacturing the glass fabric reinforcements may be assumed to be double-curved surfaces. Such great deformations significantly influence the mechanical properties of the composite structures. The deformability of the reinforcing fabrics mostly depends on the friction among the yarns, hence it is very important to examine and analyse that. One possible measurement method is the Kawabata-type shear test. The original Kawabata shear test (Kawabata's Evaluation System for Fabrics) is suitable for determining the shear properties of flexible sheets and textiles.

This work was part of a bigger project where we examined four glass woven fabric reinforcements. During the project we carried out yarn pull-out tests, modified Kawabata-type shear tests and cylindrical friction tests on the examined materials. In this paper we focus on the modified Kawabata-type shear tests and the results are demonstrated and discussed. For the measurements we applied a novel apparatus we developed that can be mounted on almost any kind of universal load machine and which makes possible both to make modified Kawabata-type shear tests, hence investigate the shear properties of sheet-like flexible materials and to carry out yarn pull-out tests on woven fabrics.

In this paper, we introduce the new apparatus and test setup, and based on the results we obtained, we propose new parameters for the evaluation of the modified Kawabata-type shear tests for woven glass fibre fabric reinforcements.

Introduction

There are several methods for investigating the shear properties of textiles from picture frame test to biaxial test with T-shaped specimen [1-5]. Probably the most famous of them is the Kawabata shear test. This test is part of a complete testing system, called KES-F (Kawabata Evaluation System – Fabrics), which consists of measuring mechanical (tensile, compressibility, bending, shear) and surface properties of fabrics. The system investigates the mechanical behaviour of fabrics under low load [6,7]. Originally, Kawabata and his co-workers developed this system in order to make quantified measurement of fabric handle, but the Kawabata shear test (in itself) is suitable for determining the shear properties of technical textiles and reinforcing fabrics as well. The mechanical properties of fabrics show a non-linear behaviour under small load. This non-linearity causes a hysteresis in the relation of load and deformation [8].

The Kawabata shear test is done by a completely automated, computer controlled device. The principle of the test can be seen in Figure 1. The measurement is made on 200x200 mm specimens. Two parallel sides of the specimen are clamped (the distance of the clamps is 50 mm) and one of them is moved sideways in order to generate shear deformation in the specimen (Fig 2/a). The rate of shear strain is $8.34 \cdot 10^{-3}/\text{sec}$. During the test the specimen is under a 10 gf/cm ($\sim 9,8 \cdot 10^{-4}$ N/m) constant normal pretension, which is generated by a weight attached rotating drum. The shear force is measured by measuring the force required to slide with, and the shear strain is measured from the resulting displacement of the slide with a shear strain detector [6-7].

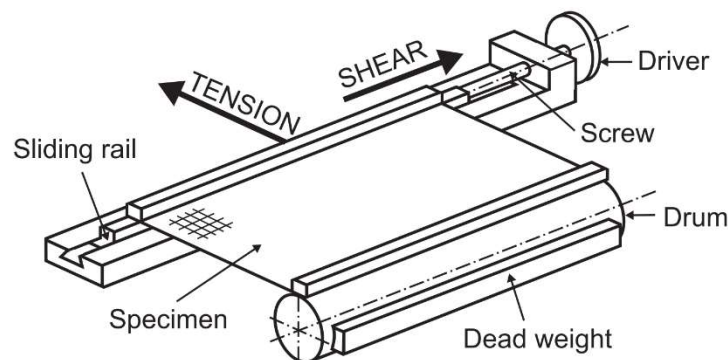

Figure 1: The principle of Kawabata shear test [1]

During the test, the shear motion changes direction as the shear angle reaches $+8^\circ$ or -8° . The result of the test is a specific shear force – shear angle diagram, which can be seen in Figure 2/b. Based on the diagram, the so-called Kawabata parameters (which describe the deformability of the fabric) can be calculated. The parameters are the following: the hysteresis of shear force at shear angle of 0.5° ($2HG$ [N/m]), the hysteresis of shear force at shear angle of 5° ($2HG5$ [N/m]) and the shear rigidity, calculated from the mean slope of the curve in the region between a shear angle of 0.5° and 5° (G [N/(m $^\circ$))] [6-7].

During this project we designed a novel apparatus, which is able to make a similar test like the Kawabata shear tester and we examined a new approach and new parameters to this test.

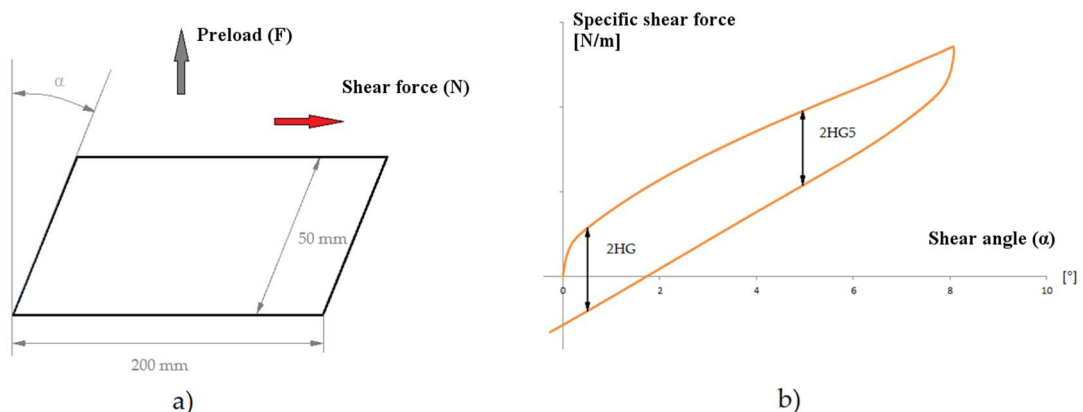

Figure 2: The shearing specimen (a) and the specific shear force – shear angle diagram (b) [9]

Experimental

Materials applied

We chose four woven glass fabric composite reinforcements for the measurements provided by Unique Textiles. The fabric reinforcements can be grouped into two pairs. Each pair had the same areal density, but a different weave pattern. The nominal data and the structural-geometrical properties of the examined materials can be seen in Table 1 and Table 2, respectively.

Sample name	Width [cm]	Weight [g/m ²]	Warp density [1/cm]	Weft density [1/cm]	Warp and weft yarns code	Weave
UTE 80P	100	80	12.0	11.4	EC 9-34	Plain 1/1
UTE 80T	100	80	12.0	11.4	EC 9-34	Twill 2/2
UTE 195P	100	195	8.0	6.0	EC 13-136	Plain 1/1
UTE 195T	100	195	8.0	6.0	EC 13-136	Twill 2/2

Table 1: The nominal data of the examined woven glass fabrics

Sample name	Yarn linear density [tex]		Yarn density [1/cm]		Weight [g/m ²]	Crimp [-]	Thickness [mm]
	Warp	Weft	Warp	Weft			
UTE 80P	34.70	33.70	12	11	79.74	0.004	0.07
UTE 80T	34.43	34.67	12	11	80.18	0.002	0.06
UTE 195P	137.7	136.4	8	6	191.1	0.006	0.20
UTE 195T	140.3	137.5	8	6	185.1	0.003	0.20

Table 2: The structural-geometrical properties of the examined woven glass fabrics

Apparatus design

We designed an apparatus which can be mounted on almost any kind of universal load machine or tensile tester. This apparatus makes possible to carry out modified Kawabata-type shear tests (hence investigate the shear properties of sheet-like flexible materials) and yarn pull-out tests on woven fabrics. In the following we introduce the shear test mode. The schematic drawing of the device (in shear test mode) can be seen in Figure 3.

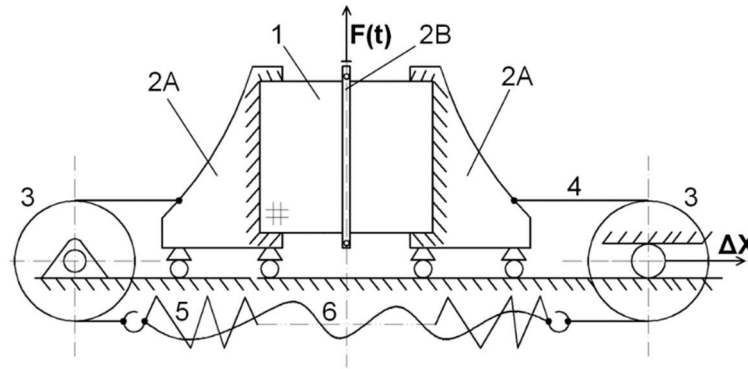

Figure 3: The schematic drawing of the designed apparatus. 1: specimen, 2A: side clamps, 2B: middle clamp, 3: rollers with appropriate bearing, 4: thin rope, 5: pretensioning steel spring, 6: strain limiting yarn

The setup of the measurement is symmetrical. There are two parallel clamps at the vertical edges of the rectangular specimen and a third, parallel one in the middle. The two parallel edges of the test specimen (Figure 3: 1) are clamped (Figure 3: 2A) and the shear deformation in the specimen is generated by the vertical motion of the middle clamp (Figure 3: 2B). The long, helical, linear characteristic spring (Figure 3: 6) is a simple but precise construction, suitable for induce the required pretension. During the test, the two side clamps can move sideways on a horizontal rail, due to the vertical force generated by the load device and the horizontal forces of the pretension spring mechanism.

The device can be mounted to the tensile tester with four bolts. Before the test, for the insertion of the specimen the whole apparatus can be turned to a horizontal position around the motherboard after removing two positioning pins. As soon as the specimen is well positioned and well-fixed, the apparatus can be tilted back to the working position and fixed by the pins. Then the locking levers are to be loosened, thus the side clamps can again slide freely on the rail. The pretension can be applied by the adjustment gears until reaching the proper strain of the spring. The middle clamping unit is then fixed and hence the specimen is ready for the test. The apparatus mounted on a tensile test machine (in shear test mode) can be seen in Figure 4.

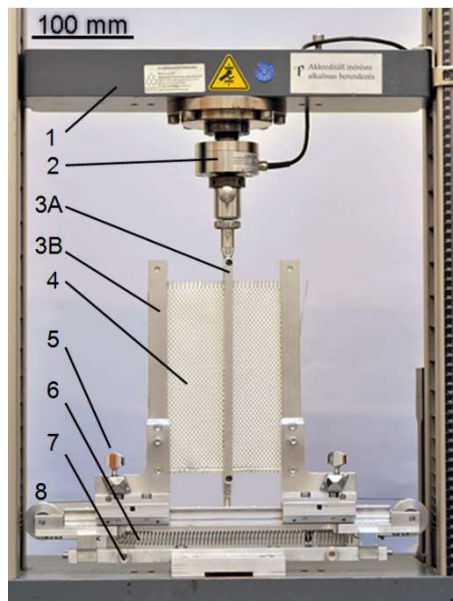

Figure 4: The apparatus mounted on a tensile test machine 1: crosshead, 2: force sensor, 3A: middle clamping unit connected to the crosshead of the tensile tester, 3B: side clamps, 4: test specimen, 5: gears for adjusting pretension, 6: pretension spring, 7: fixing bolts, 8: rollers with bearings

Test parameters

The apparatus was mounted on a Zwick Z005 type universal load machine and the speed of the crosshead was 50 mm/min. The shear force was measured by a force sensor with a measuring range of 20 N, having a resolution of 1 mN. The shear tests were carried out with 20 N pretension force, i.e. 1 N/cm (related to specimen width) induced by the spring. The displacement of the middle clamp was ± 20 mm from the neutral position, therefore the shear angle range was $\pm 23.6^\circ$ and a whole shear cycle was investigated. It should be noted that at big shear angles, bending also occurs in the yarns. Hence this measurement is a modified Kawabata test up to 8° shear angle, but we can also get information about the textile at big angles, though there is not only pure shear in the specimen. Specimens were clamped and tested in warp direction. The size of the specimens was 200x200 mm, the width of the shear zone was 2x50 mm.

We performed five modified Kawabata-type shear tests (cyclic test, up to two full hysteresis loop cycle) on each material (on five different specimens) and from each measured force-displacement curve we calculated a specific shear force $N(t)$ [N/m] – shear angle $\alpha(t)$ [$^\circ$] curve with equation (1) and (2):

$$N(t) = \frac{F_t(t)}{2H} \quad (1)$$

$$\alpha(t) = \arcsin\left(\frac{u(t)}{X_0}\right) \frac{180}{\pi} \quad (2)$$

where $F_i(t)$ [N] is half the force measured by the tensile test machine, H [m] is the length of the specimen, $u(t)$ [m] is the displacement of the middle clamp and X_0 [m] is the half gripping distance.

Results and Discussion

A typical calculated two-cycle hysteresis curve of each tested material can be seen in Figure 5.

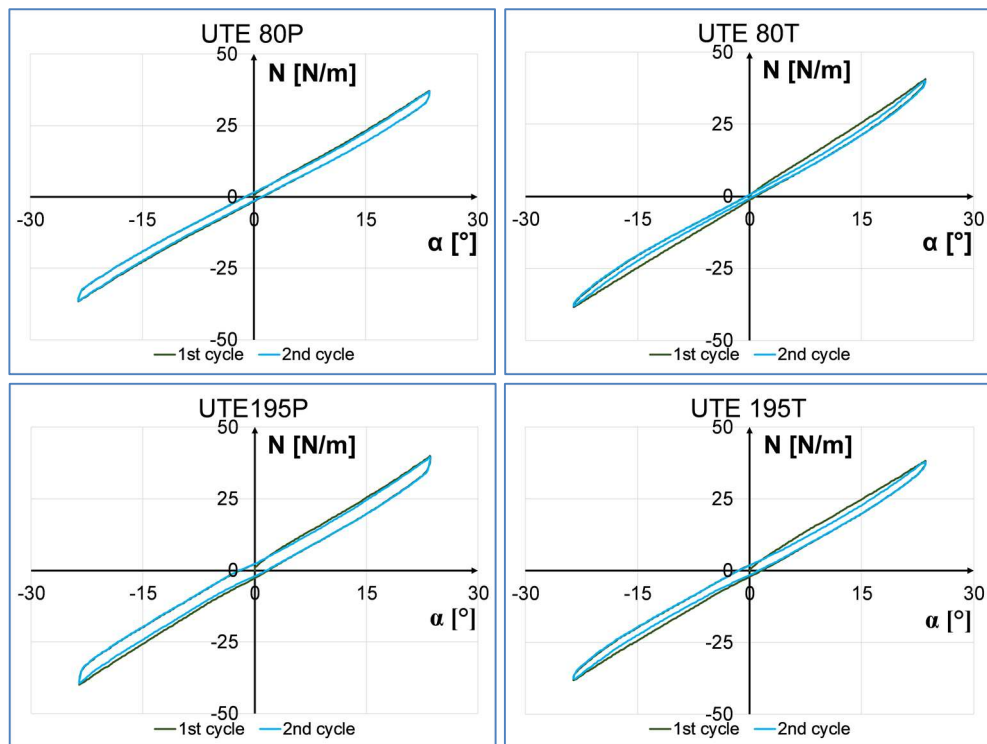

Figure 5: Typical shear curves of the tested materials

The measured curves show that the apparatus we designed is suitable to make the modified Kawabata-type shear tests and able to do cyclic tests. Based on the measured curves we determined the Kawabata parameters on the 1st cycle curve not only in the positive, but also in the negative angle region in every case. Besides the Kawabata parameters, we defined and determined a new parameter: $2HG15$ [N/m], which is the hysteresis of shear force at shear angle of 15° . This value is out of the range of the original Kawabata-test and at this state of the measurement there is not only pure shear in the specimen, but also bending. The results are summarized in Figure 6, where positive/negative means that the given parameter was determined on the positive/negative angle region of the curve.

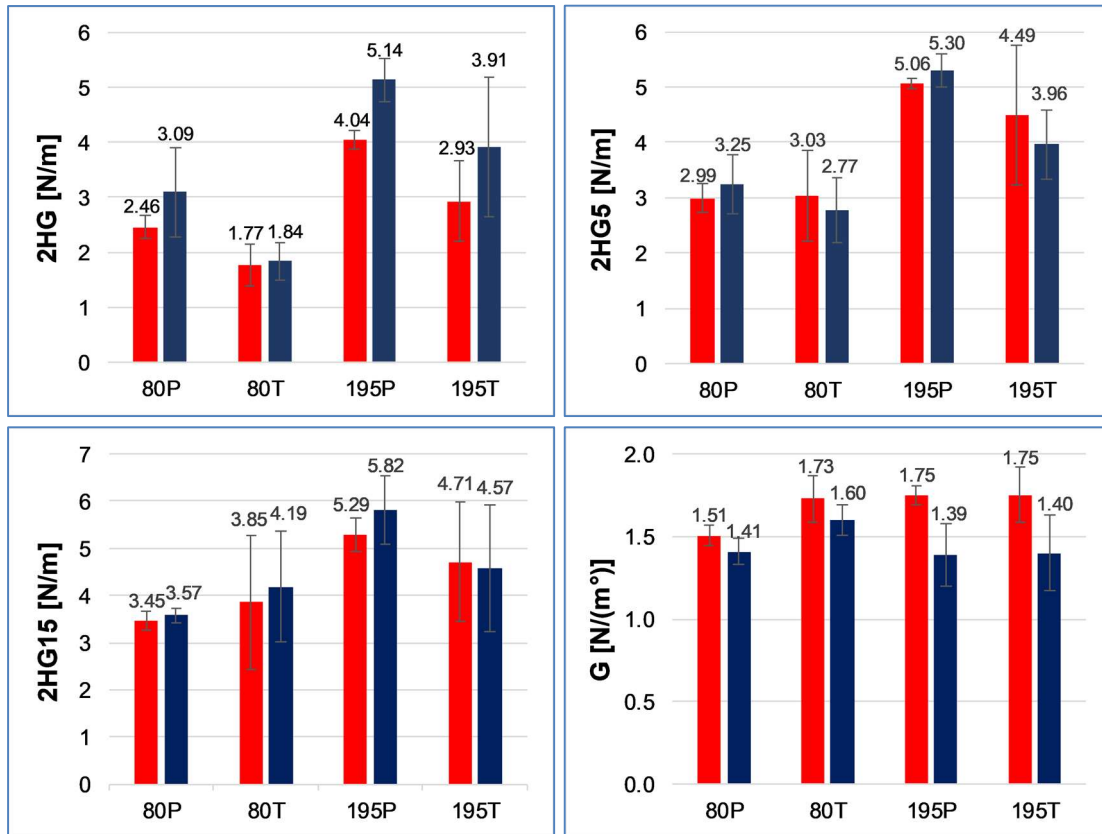

Figure 6: Measurement results (red: positive, blue: negative)

Considering the standard deviations, it can be stated that the fabric reinforcements with smaller area density has smaller $2HG$, $2HG5$ and $2HG15$ values than the fabric reinforcements with bigger area density in almost every cases and the same applies to the twill vs. the plain weave. This results are consistent with our expectations, because they mean that fabrics with smaller area density and looser weave pattern (twill weave) are easier to deform and more flexible. There is no significant difference in shear rigidity values, only in the case of fabrics with 80 g/m^2 area density is smaller than the others. This is probably due to the fact that they are made of the same material with the same surface treatment and the acting friction force between the fibres is almost the same, nevertheless the weave pattern.

Despite the fact that at big shear angles the stress is not only shear, but also bending there is no significant difference between the $2HG5$ and $2HG15$ values at any of the examined materials. Based on these results, it can be stated that the range of the measurement could be extended to larger angles in case of woven glass fabric reinforcements.

We found that the sections related to the positive and the negative angles are quite similar and the obtained values of the parameters are not significantly different. Still, there is an advantage of the cyclic tests as calculating the $2HG$, $2HG5$ and $2HG15$ parameters is possible from multiple cycles as the resulting curves of the cycles overlap.

In the future, we would like to repeat these tests on a real Kawabata shear tester and compare the results we measured with the two different apparatus.

Summary

We developed a novel apparatus that can be mounted on almost any kind of universal load machine and it makes possible to carry out both modified Kawabata-type shear tests and yarn pull-out tests. With the developed apparatus we made modified Kawabata-type shear tests on four woven glass fabric composite reinforcements obtained from the same manufacturer. The fabric reinforcements can be divided into two pairs. Each pair had the same areal density (80 or 195 g/m²), but had a different weave pattern (plain or twill). Based on the measured shear hysteresis loops, it can be stated that the apparatus is suitable to make Kawabata-type shear tests and able to do cyclic tests. From the measured force-displacement curves we calculated a specific shear force – shear angle curve. Based on these calculated curves we determined the Kawabata parameters and defined one new parameter (*2HG15*) in every case, but not only in the positive, but also in the negative angle region.

Considering that the hysteresis loops from a multiple-cycle shear test overlap each other, *2HG*, *2HG5* and *2HG15* parameters can be calculated from the resulting curves of the cycles.

Despite of the fact that at big shear angles the stress state does not only include shear, but also bending, there is no significant difference between the *2HG5* and *2HG15* values at any of the examined materials, hence the range of the measurement could be extended to larger angles in case of woven glass fabric reinforcements.

Acknowledgements

This paper was supported by the János Boyai Scholarship of the Hungarian Academy of Sciences and by the ÚNKP-19-2 and ÚNKP-19-3 New National Excellence Program of the Ministry for Innovation and Technology.



Literature

1. Galliot C., Luchsinger R. H., The shear ramp: A New Test Method for the Investigation of Coated Fabric Shear Behaviour – Part I: Theory; Composites Part A: Applied Science and Manufacturing 41, 1743-1749, (2010).
2. Galliot C., Luchsinger R. H., A new test method for the investigation of coated fabric shear behaviour – Part II: Experimental validation; Composites Part A: Applied Science and Manufacturing 41, 1750-1759, (2010).
3. Domskiené J., Strazdiené E., Investigation of Fabric Sheer Behaviour; Fibers & Textiles in Eastern Europe 13, 26-30, (2005).
4. Lebrun G., Bureau N. M., Denault J., Evaluation of Bias-Extension and Picture-Frame Test Methods for the Measurement of Intraply Shear Properties of PP/glass Commingled Fabrics; Composite Structures 61, 341-352, (2003).
5. Zhu B., Yu T. X., Tao X. M., Large Deformation and Slippage Mechanism of Plain Woven Composite in Bias Extension; Composites Part A: Applied Science and Manufacturing 38, 1821-1828, (2007).
6. Kawabata S., Nonlinear mechanics of woven and knitted materials; in: Composite materials series; Textile structural composites (editor: Chou T.W., Ko F.K.), Elsevier, Amsterdam, 3, 67–116, (1989).
7. Kawabata S., The standardization and analysis of hand evaluation; Textile Machinery Society of Japan, Osaka, (1980).
8. Li Y., Dai X-Q.; Fabrics, in: Biomechanical engineering in textiles and clothing (editors: Li Y., Dai X-Q.); Woodhead Publishing Limited, Cambridge, 199-222, (2006).
9. Halász M., Novel methods for testing the mechanical properties of textiles and textile reinforced flexible composite sheets at the BME Department of Polymer Engineering; Part 1 (in Hungarian), Magyar Textiltechnika 69, 29-34, (2017).